



The DNA of tech.™

# Tantalum Capacitors

Jon Rhan – Senior Product Marketing Manager

Vishay Tantalum Division

# Dielectric Comparison Table

Characteristic	MLCC COG/NPO	MLCC X7R	MnO2 Tant	Polymer Tant	Wet Tant	Aluminum Electrolytic	PP Film	PPS Film	PET Film	PEN Film	EDLC
Temperature Range	-55 to +125C	-55 to +125C	-55 to +200C	-55 to +125C	-55 to +230C	-55 to +150C	-55 to +125C	-55 to +125C	-55 to +125C	-55 to +125C	-40 to +85C
Delta Cap with Temp	0 +/- 30ppm	+/-15%	+/-10%	+/-10%	+30 to -50%	+25 to -30%	+/-1,5%	+/-1.5%	+/-5%	+/-5%	
DC Voltage Coefficient @ VR	Negligible	-20 - -50%	Negligible	Negligible	Negligible	Negligible	Negligible	Negligible	Negligible	Negligible	Negligible
Aging Rate (%/dec hr)	Negligible	1-3%	N/A	N/A	N/A	N/A	Negligible	Negligible	Negligible	Negligible	N/A
Dissipation Factor %	0.1	2.5	8	8	8	>5	0.05	0.2	N.A.	0.8	N/A
ESR - relative	low	moderate to high	high	low to moderate	moderate to high	high	very low	very low	low	low	high
Dielectric Absorption (%)	0.6	2.5	0.5	0.5	0.5	N. A.	0.05	0.2	0.5	1	N/A
Capacitance Range	0.1pF - 0.1uF	100pF - 47uF	0.1uF to 2200uF	1uF to 2800uF	1uF - 72000uF	0.1uF - 1 F	100pF to 100uF	100pF to 10uF	1000pF to 10uF	1000pF to 10uF	1F to 500F
Capacitance Tolerance	1 - 10%	5%, 10%, 20%	5%, 10%, 20%	5%, 10%, 20%	5%, 10%, 20%	20%	5%, 10%, 20%	2.5%, 5%, 10%	5%, 10%	5%, 10%	-20% / 50%
Failure Mode	Short	Short	Short	Short	Short	Short, Open	Open	Open	Open	Open	Open
Self Healing	No	No	Limited	Limited	Yes	Limited	Yes	Limited	Yes	Yes	No
Reliability	High	moderate	High	High	High	Low	High	High	High	High	Low
Piezoelectric Effect	No	Yes	No	No	No	No	No	No	No	No	No
Resistance to thermal & mechanical shock	Low	moderate	high	high	high	Moderate	High	High	High	High	Moderate
Polar	No	No	Yes	Yes	Yes	Yes	No	No	No	No	Polar

# Maximum Capacitance Per Technology

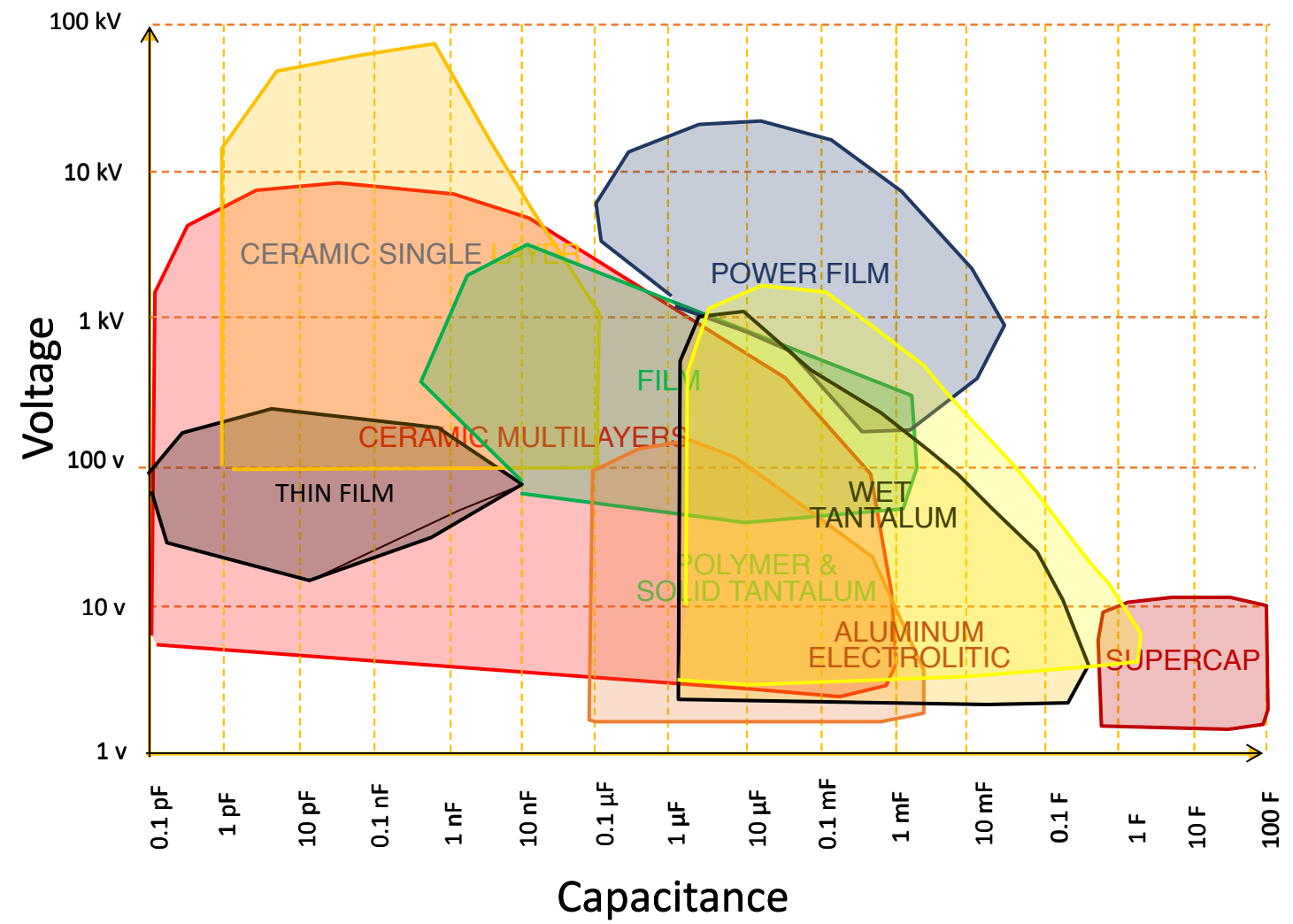

# Capacitor Size

Rating: 1μF 100VDC



## Tantalum

150D / M39003/01  
MnO<sub>2</sub>  
Max T: +125°C  
Volume: 105mm<sup>3</sup>



~ 9x size

## Film

MKT373 (Compact size)  
Max T°: +105°C  
Volume: 963 mm<sup>3</sup>



~ 3x size

## Aluminum Electrolytic

MAL213229108E3  
10,000 hours life  
Max T°: +85°C  
Volume: 300 mm<sup>3</sup>



~ 1/5 size

## Ceramic

VJ1210Y105KXBTW1BC  
Type II - X7R  
Max T +125°C  
Volume: 18 mm<sup>3</sup>

# History of Tantalum Capacitors

- Tansitor Electronic developed the first tantalum capacitors with wound tantalum foils and wet electrolyte in 1930 for the military.
- Bell Labs invented the solid tantalum capacitor in the early 1950's.
- Sprague Electric innovated the design to commercially manufacture these in 1954, the “drops”
- Conductive polymers were developed in 1975, dramatically reducing parasitic resistance. NEC introduced polymer tantalums in 1993, with Sanyo close behind in 1997.





# Tantalum Powder Surface – Volumetric Efficiency

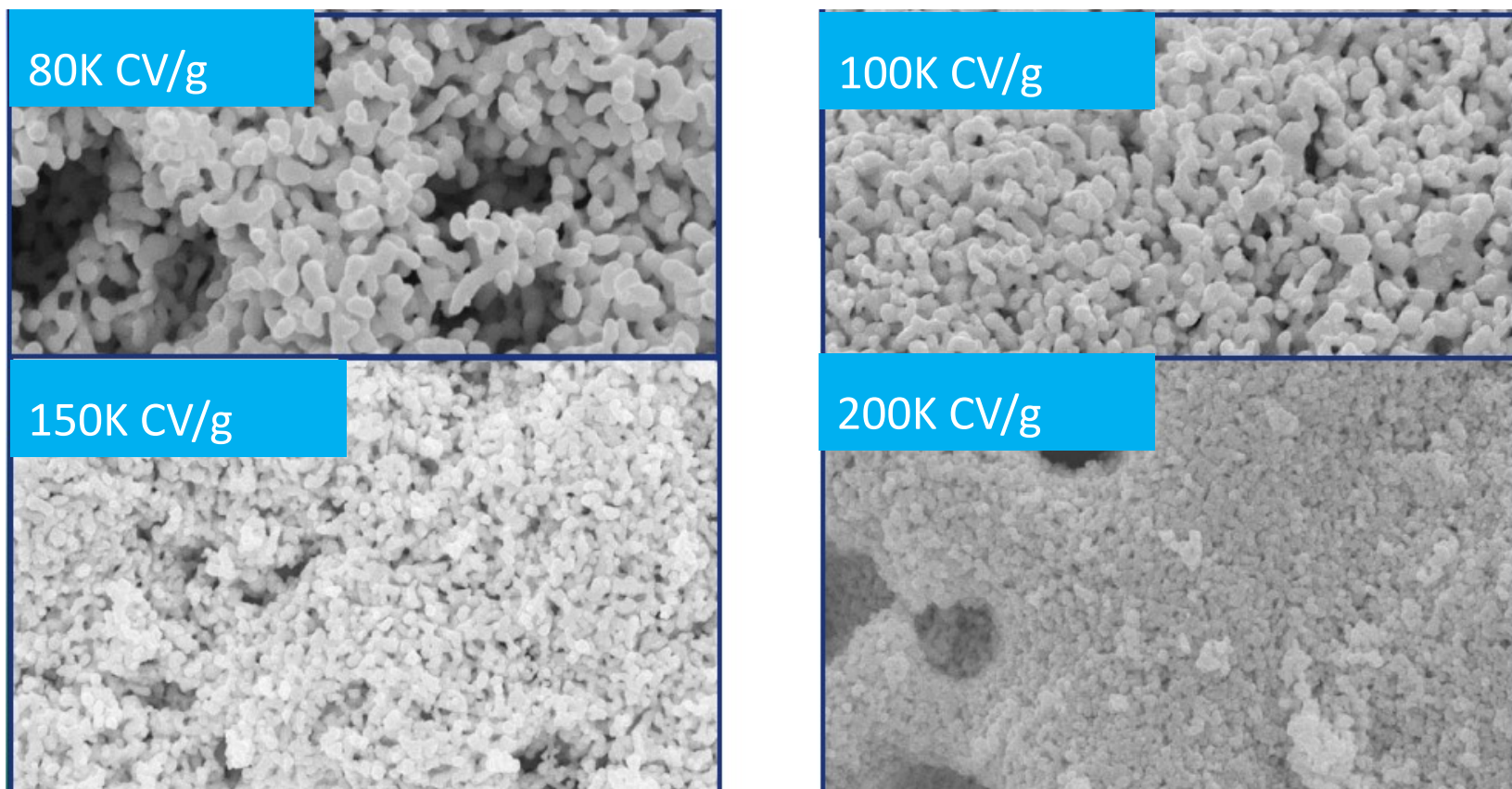

For a given volume of tantalum material, the smaller the particle size (higher CV/g), the larger the surface area (A).

# Three Tantalum Capacitor Classes:

- Wet Cathodes
- Solid Polymer Cathodes
- Solid MnO<sub>2</sub> Cathodes

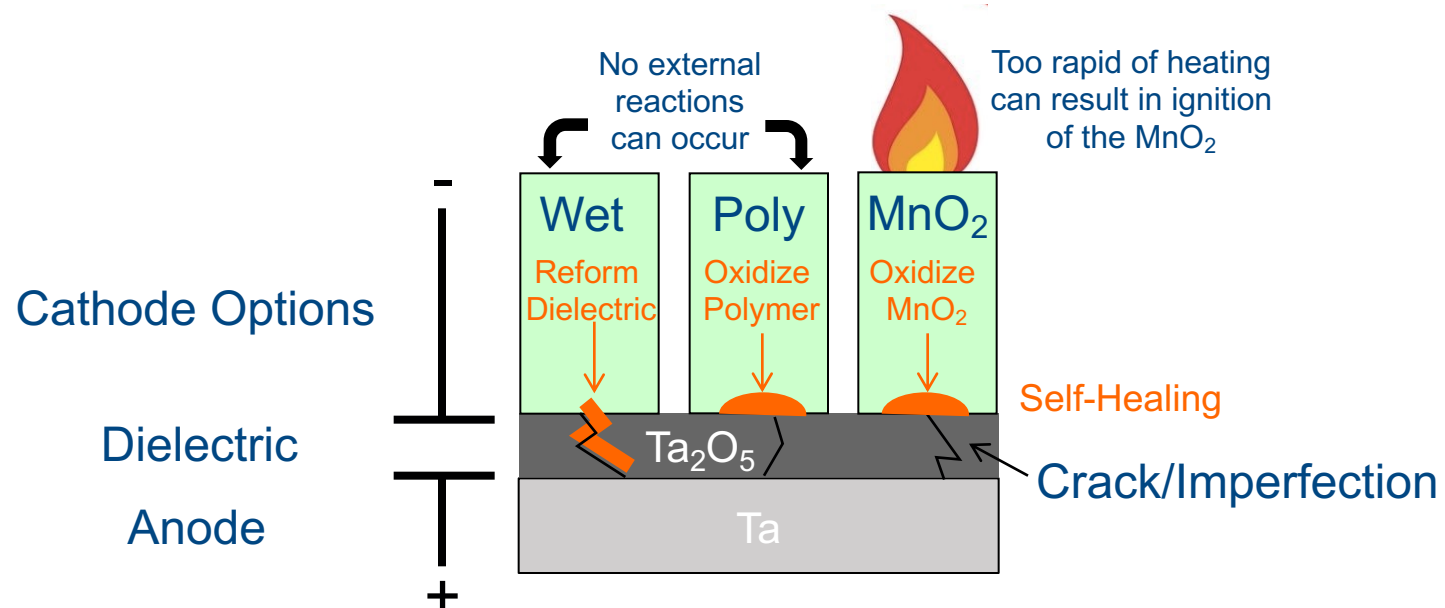

# Why Choose Wet Tantalum Capacitors

- ✓ Best in class volumetric efficiency; Energy densities up to 2J/cc
- ✓ Wide voltage range; 10V-150V
- ✓ All Tantalum, hermetically-sealed case; No humidity related wear out mechanism
- ✓ Non-burning failure mode
- ✓ Available in surface mount and axial designs
- ✓ No wear-out mechanism; qualified for
  - ✓ 10,000hrs; MIL products; established reliability
  - ✓ 2,000hrs; 85°C at RV, 125°C at 67% RV
  - ✓ 1,000hrs at 200°C at 50-60% RV
- ✓ Capable to withstand harsh mechanical conditions/environment suitable for various AMS applications
  - ✓ 300 cycles thermal shock -55°C +125°C
  - ✓ 500g Shock
  - ✓ 80g high frequency vibration
  - ✓ 54g random vibration



# Axial Wet Ta Capacitor Construction

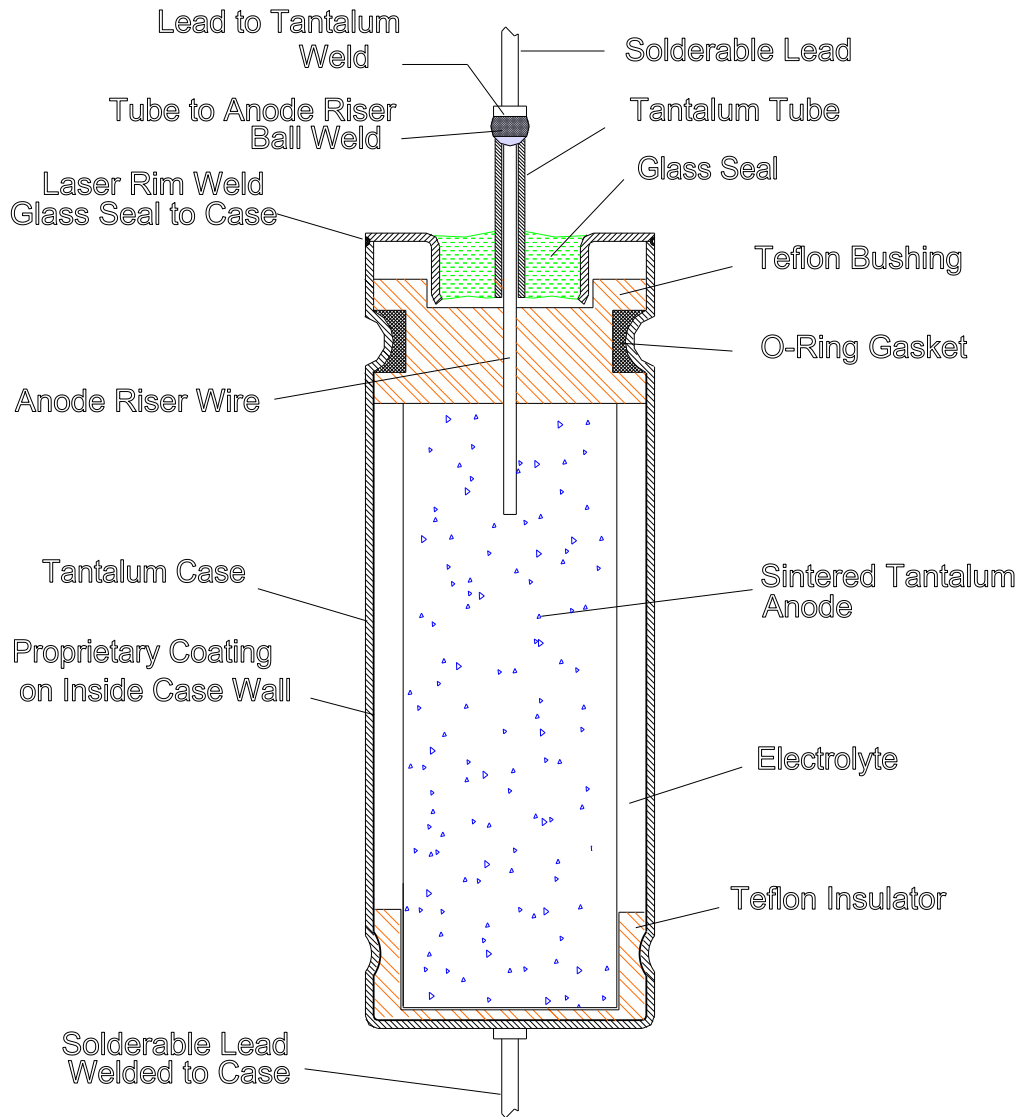

# Capacitor Construction

## Structure of Solid Tantalum Pellet

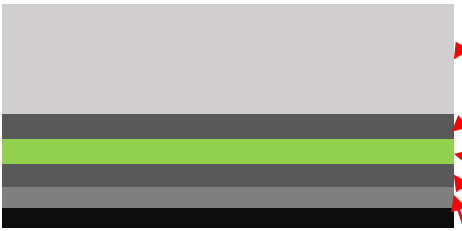
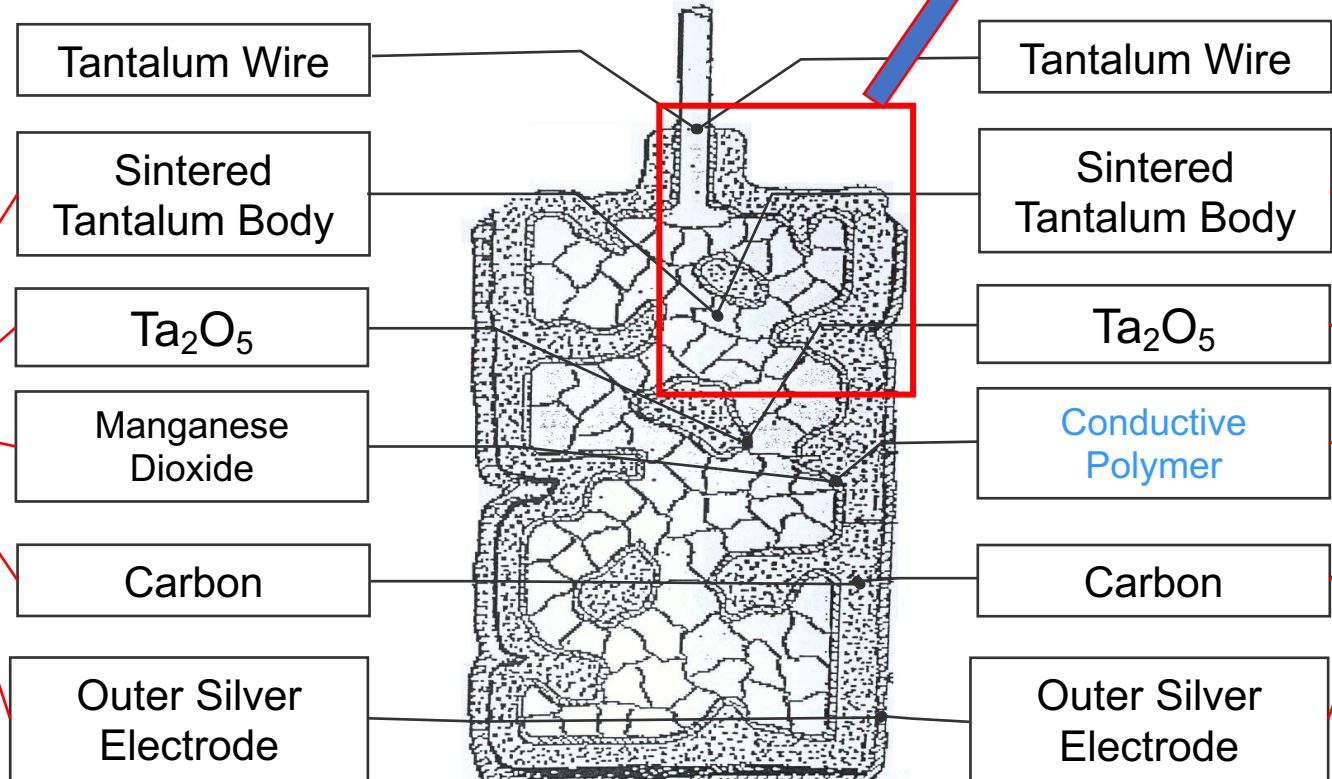
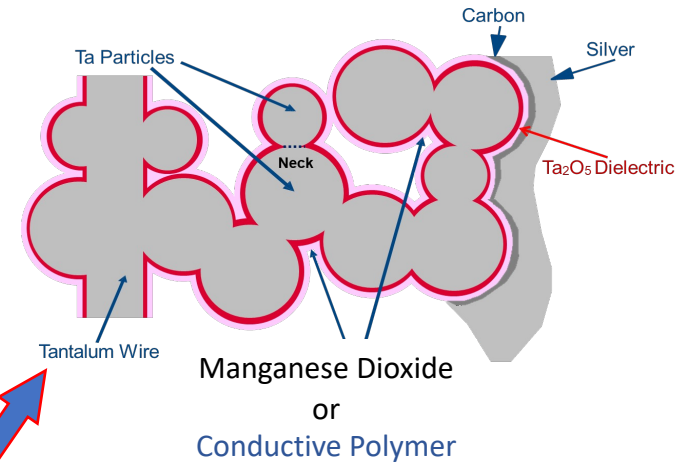

# Vishay - Tantalum Division – Solid Capacitor Construction

## Tantalum Capacitor

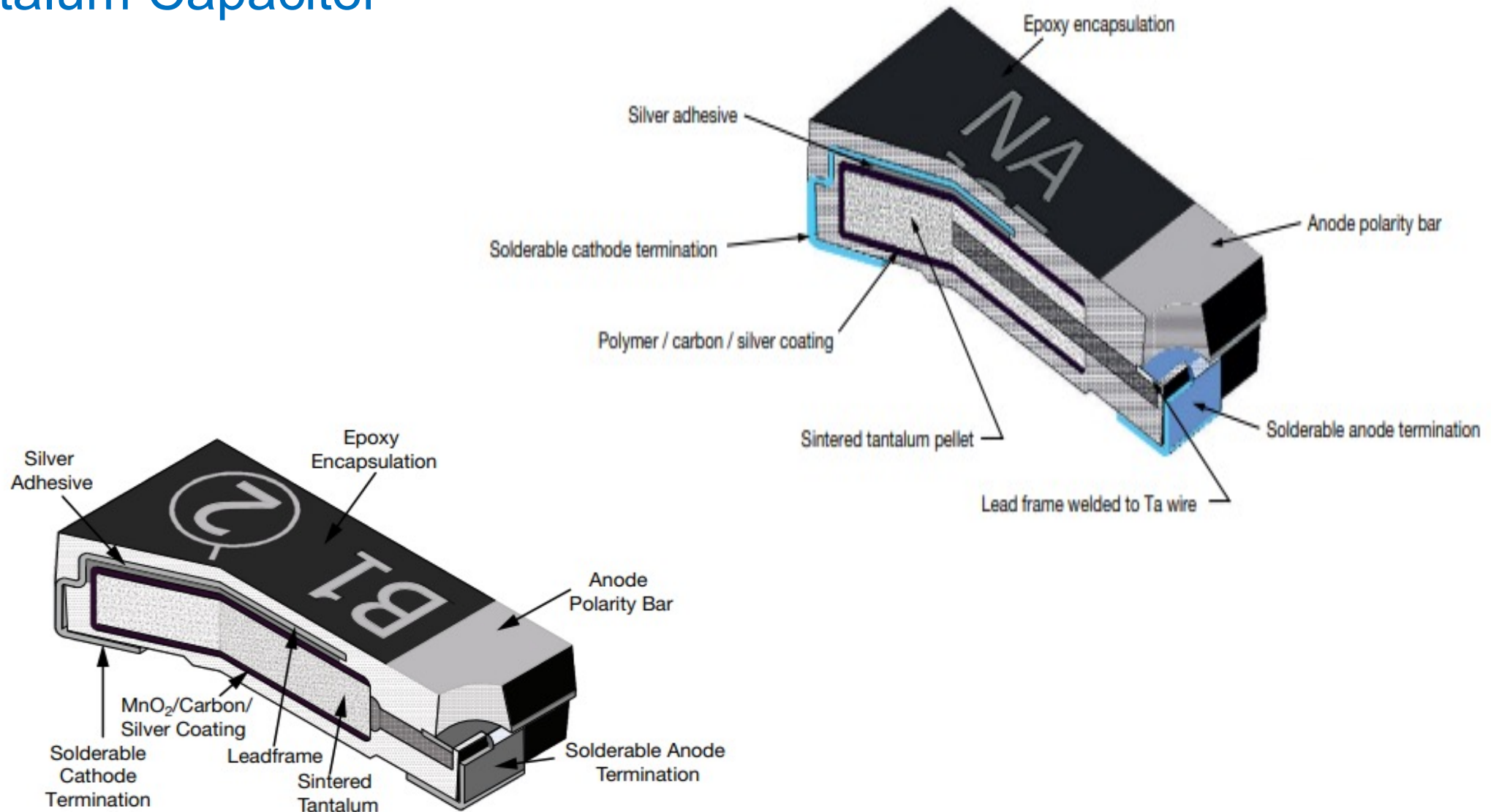

# Vishay's AnodeXpert Tech History

1. Since early 90's Vishay pioneered usage of advanced Tantalum anode technology including:
  - Liquid delubrication
  - Magnesium deoxidation
  - Anode wire welding
2. This advanced Tantalum anode technology allows Vishay to produce defect-free dielectric films essential for reaching:
  - Low DC leakage
  - Long term reliability
  - Improved ability to withstand reflow stress
3. Statistical DCL Screening at Elevated Temperature and Voltage along with MIL-PRF-55365 style screening result in highly reliable products suitable for AMS applications.

# Statistical DCL Screening at Elevated Temperature and Voltage

(Patent No.: US 10,381,166 B2 (45) Date of Patent: Aug. 13, 2019)

## Screening process steps:

- 100 % electrical test at  $V_r$ , room temperature, with  $[Avg + 3\sigma]$  statistical limit: much lower than 0.1 CV (450 uA)
- Hot DCL sample test at elevated temperature and voltage  $> V_r$ . Test voltage derived from BDV distribution
- Statistical analysis of sample test in order to define new HDCL test limit  $[Med, \sigma]$
- Perform hot DCL test for entire lot with  $[Med + 2\sigma]$  statistical limit

100 % electrical test @  $V_r$ ,  
RT DCL, uA

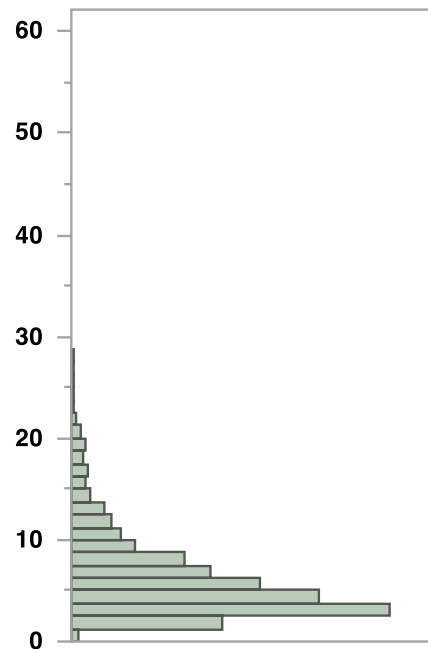

T54 150  $\mu$ F - 30 V EE

Hot DCL test  
DCL, uA

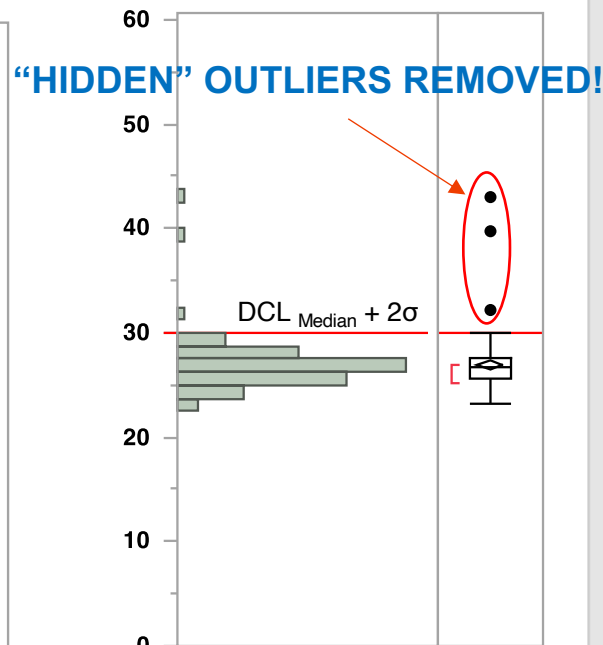

**BDV is SIGNIFICANTLY HIGHER!**

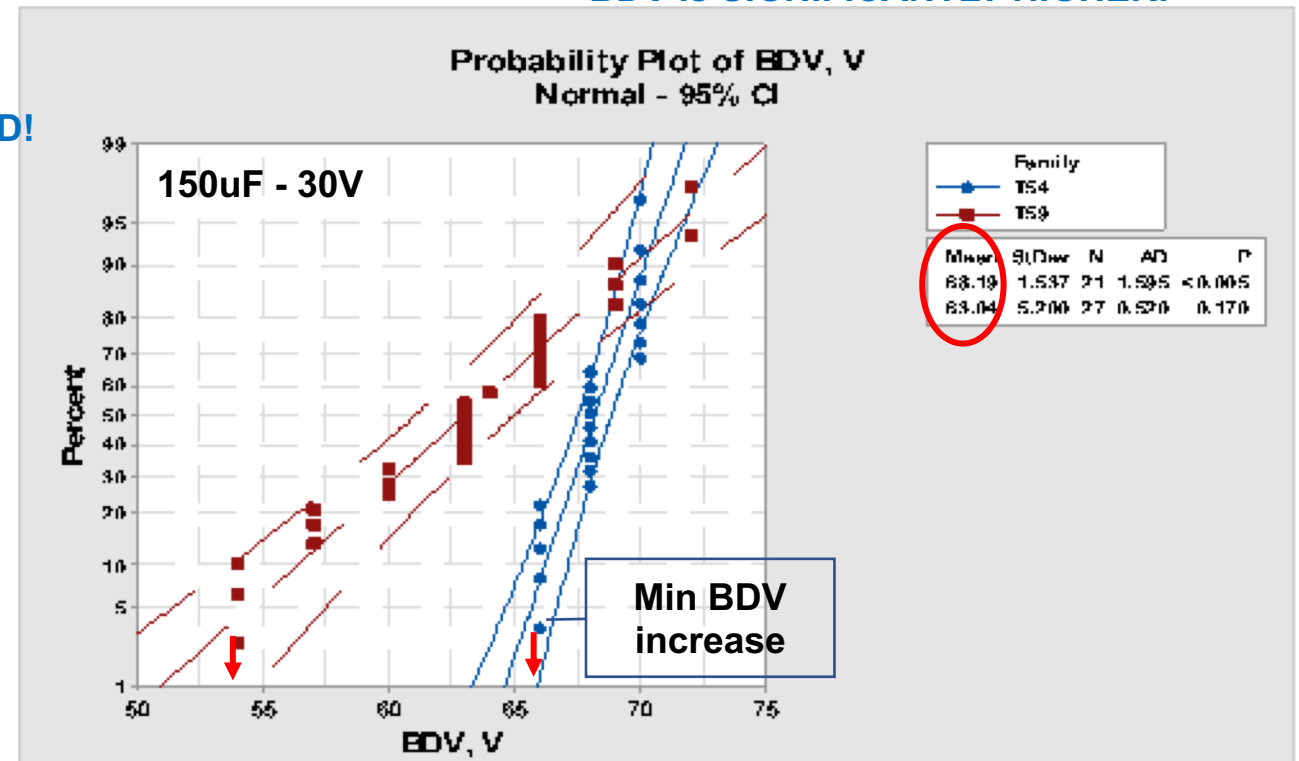

# T54 150uF - 30V EE: 10,000h Load Life Test @85°C, Rated Voltage

N=80

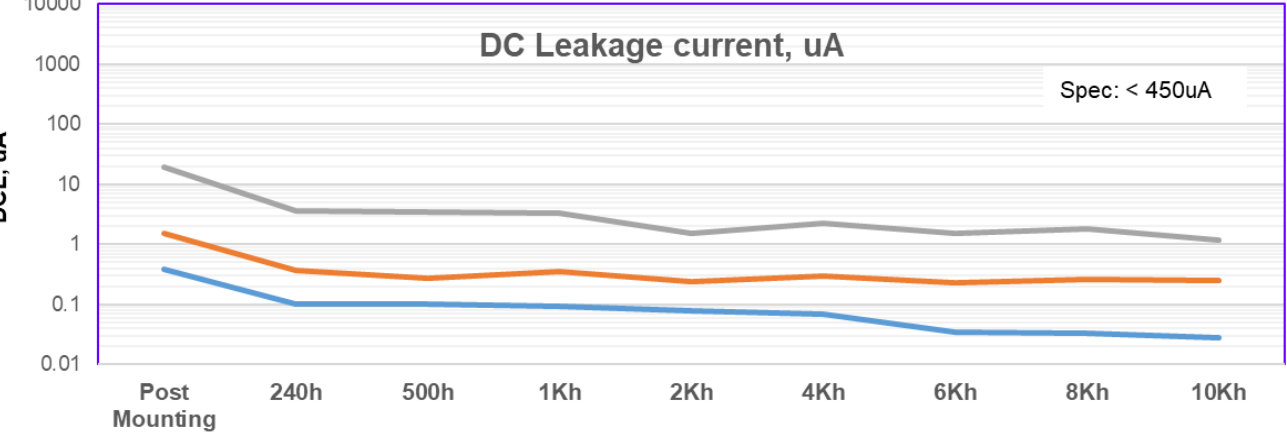
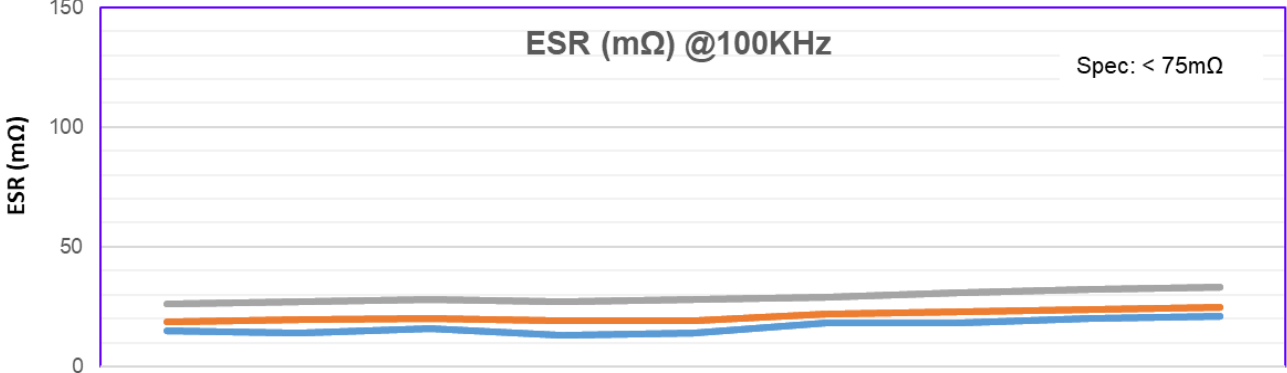
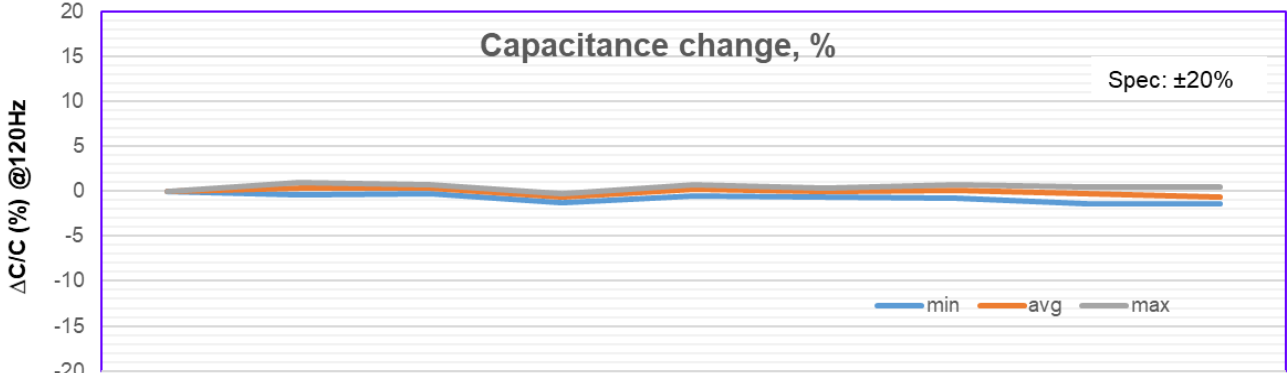



# Polymer Advantages Over Other Technologies

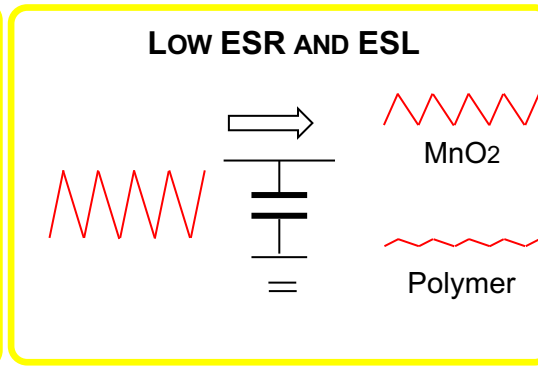
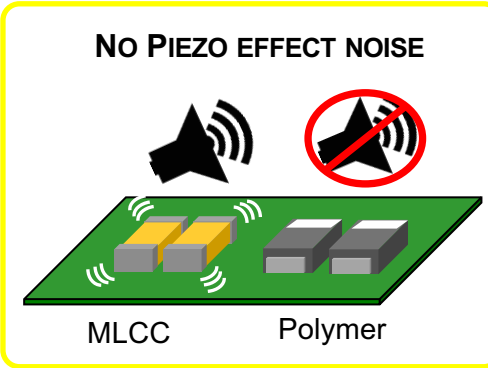
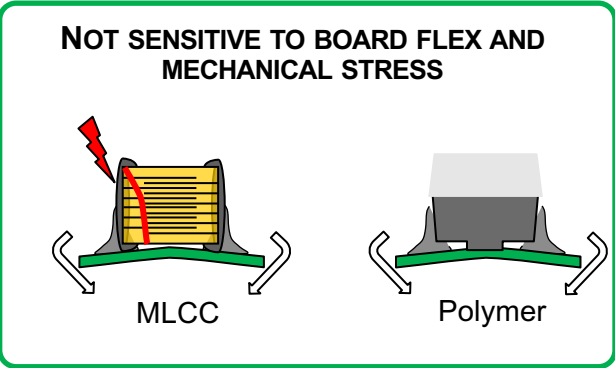
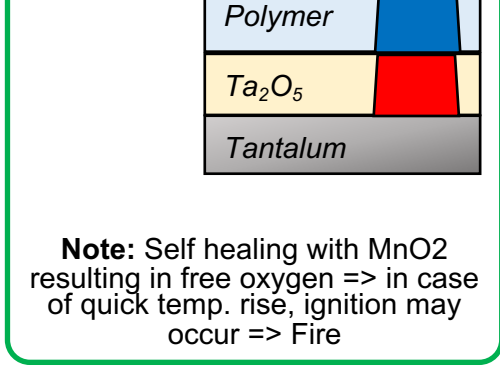
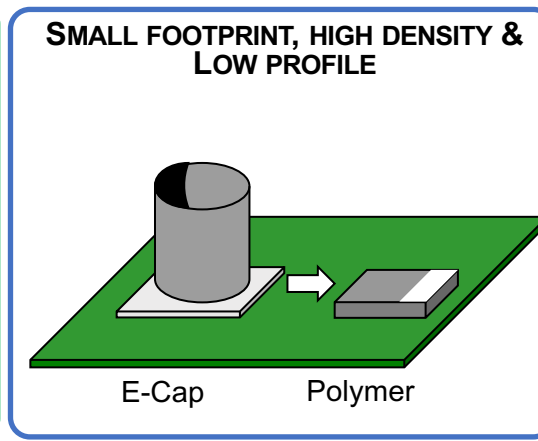
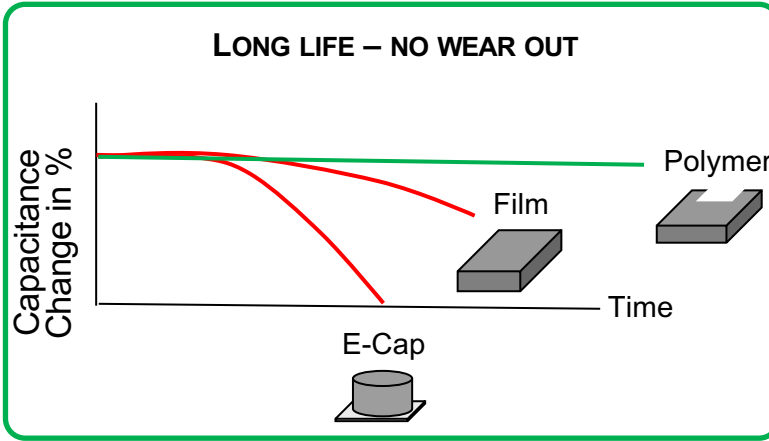
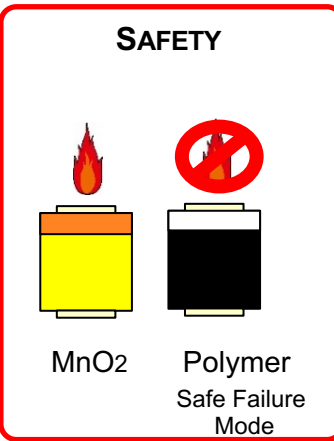
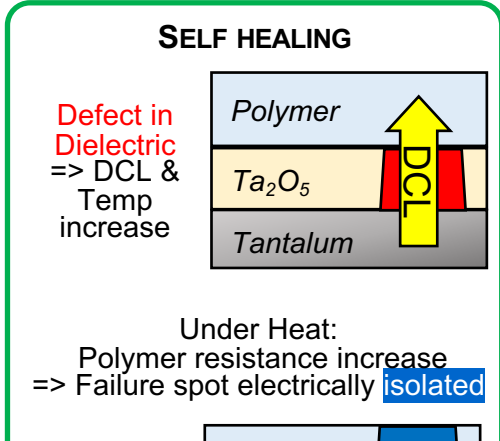
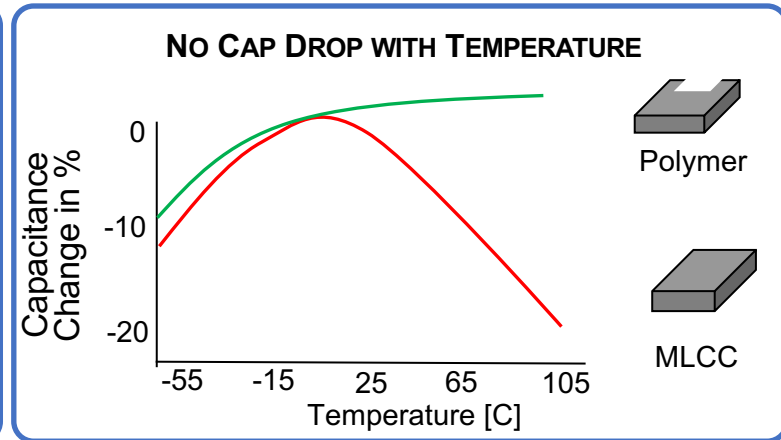
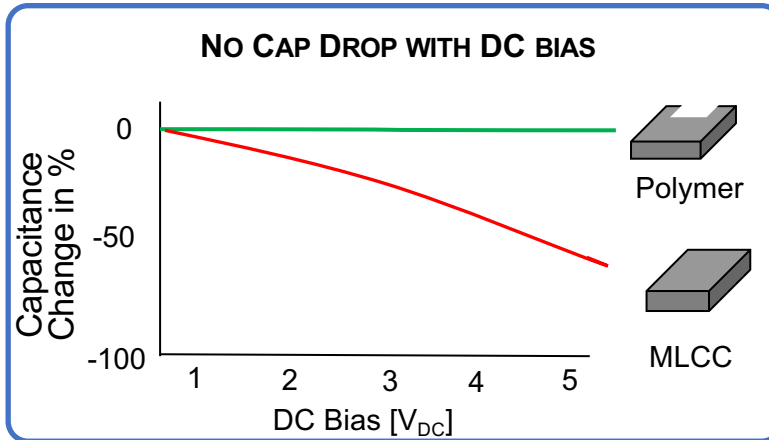
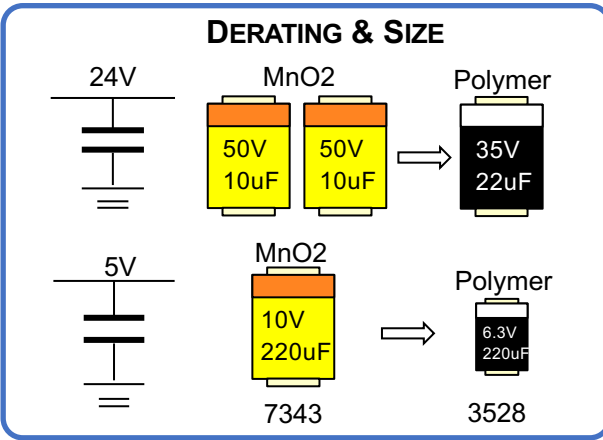

# Tantalum Reliability and Derating

- These two factors, *temperature and voltage*, are what drive lifetime.
- The cathode system changes the reliability as does the cap series inside that level. An example would be STE vs. M39006. This is not to say that a commercial part can't reach the same level of lifetime, but they are not designed to do so. Derating plays an important factor in lifetime .
- Unfortunately, we cannot say one level of derating fits all tantalums. Each type has it's own rules. While polymer is 20% derate, MnO<sub>2</sub> tantalums is 50% derate and wets are 10-20% derate.
- Application also plays into this, as different uses require more reliability than others.

# Wet Tantalum Life Prediction Curve

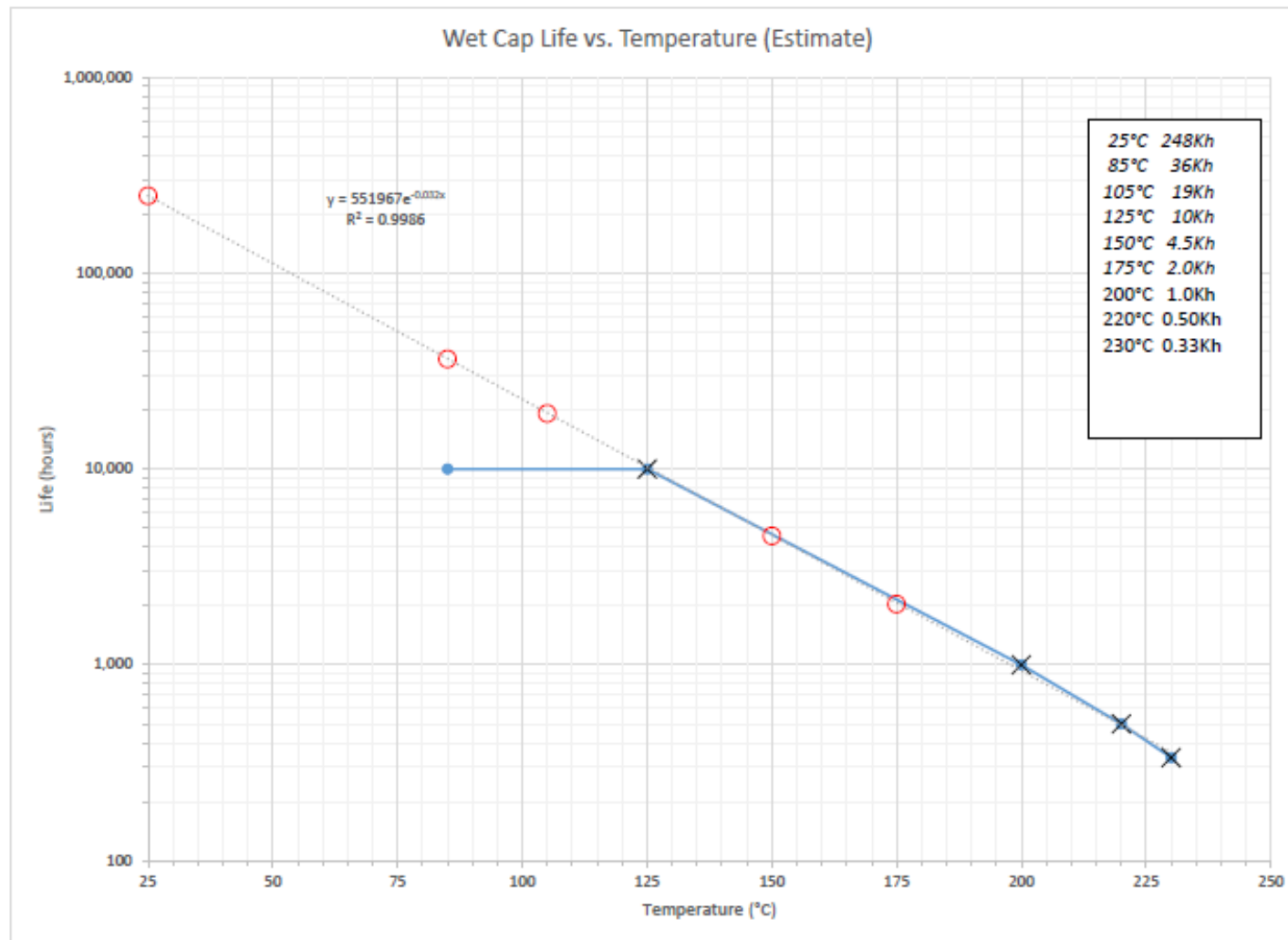

# Failure Mechanism of MnO<sub>2</sub> (Conventional Solid Tantalum Capacitor)

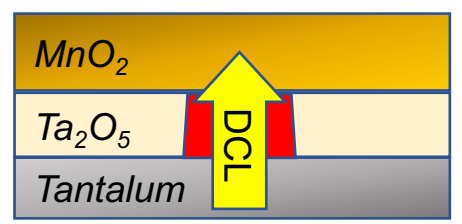
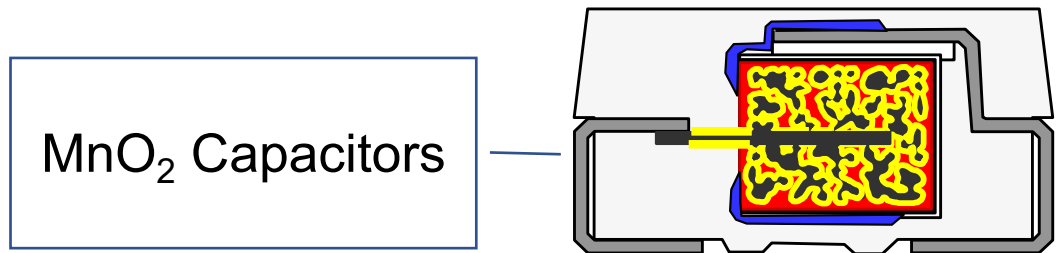

- Temperature increase to ~500°C.
- Under heat  $MnO_2 \rightarrow Mn_2O_3 + O$ .
- Highly resistive  $Mn_2O_3$  electrically isolates failure area.
- Released Oxygen heals  $Ta_2O_5$  dielectric.

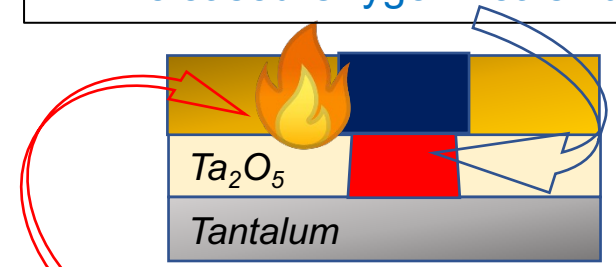

- In case of quick temperature rise the ignition may occur.

1. Defect in dielectric causes elevated DCL
2. As leakage current increased, local temperature would increase
3. Heat will help self healing on  $Ta_2O_5$  layer and form  $Mn_2O_3$  to isolate failure area
4. As the local temperature could reach 500°C and oxygen exists in the process, quick temperature rise\* may trigger ignition

\*Quick temperature rise may be caused by overvoltage operations

# Why Polymer Is Safer – Polymer Self Healing Process

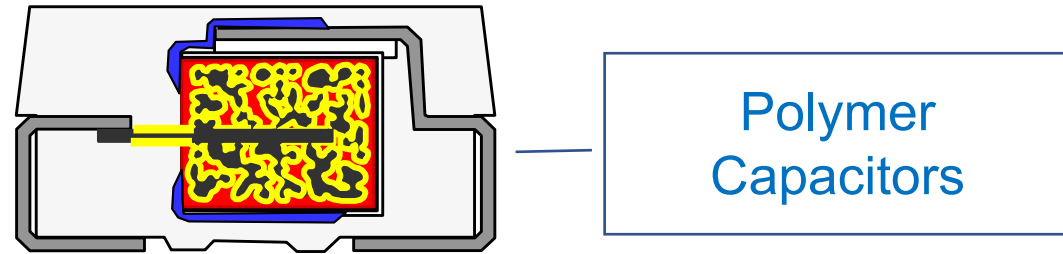

1. Defect in dielectric causes elevated DCL
2. As leakage current increased, local temperature would increase
3. Heat will void the connection of the failure spot and stop the current flow through it
4. As there is no oxygen involved in the process, ignition cannot occur.

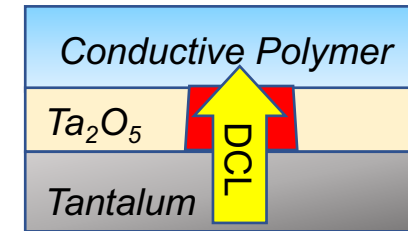

- Temperature increase to  $\sim 300^\circ\text{C}$ .
- Conductive polymer resistance increases under heat.
- Failure spot electrically isolated.

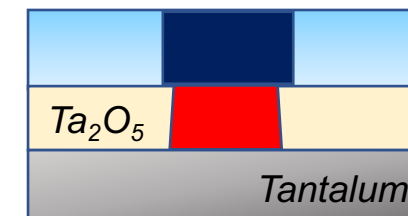

- No Oxygen available in the system, the ignition cannot occur!

## Why Derating Is Needed

- Technically, all kinds of tantalum capacitors could operate in rated voltage if failure rate @1000hrs is not a concerns to the applications.
- Industrial generally accepts 0.1% failure rate at 1000hrs and to achieve it, derating is needed.
- MnO<sub>2</sub> and Polymer is with different acceleration model due to technology different making the derating different.

Parameter	Basic Failure Rate	MnO <sub>2</sub> capacitors	Polymer capacitors
Reference document		MIL-HDBK-217F Notice 2	MIL-PRF-32700
Voltage acceleration model	N/A	$VAF [\pi_v] = \{S/0.6\}^{17} + 1, S = \frac{V}{V_r}$	$VAF = (V_R/V)^{VRE}$
Voltage Ratio exponent [VRE]	-	-	16
Derating [V/V <sub>R</sub> ]	1	0.5	0.8
Voltage acceleration factor [VAF]	1.0	23.2	35.5
Temperature acceleration factor [TAF]	1.0		
Number of units tested (N), pcs	100		
Test hour per unit (t), hours	1000		
Number of failures (m), pcs	0		
Chi-Square @ confidence level (α)	4.6		
Confidence level (α)	0.9		
Failure Rate FR, % 1000 hours	2.3%	0.1%	0.1%
MTTF, years	4.96	115	176



# What is Weibull?

Weibull is a method for failure rate (FR) prediction, based on representative sample behavior study.

## Conditions

- 1.3 to 1.53 Rated Voltage
- 40 Hours minimum at +85°C

## Benefits

- Eliminates Infant Mortality Failures
- Eliminates Lot to Lot reliability performance variability.
- Only lots with decreasing FR are accepted.

“Bathtub Curve” describes failure rate vs. time of engineered systems (e.g. cars) or components.

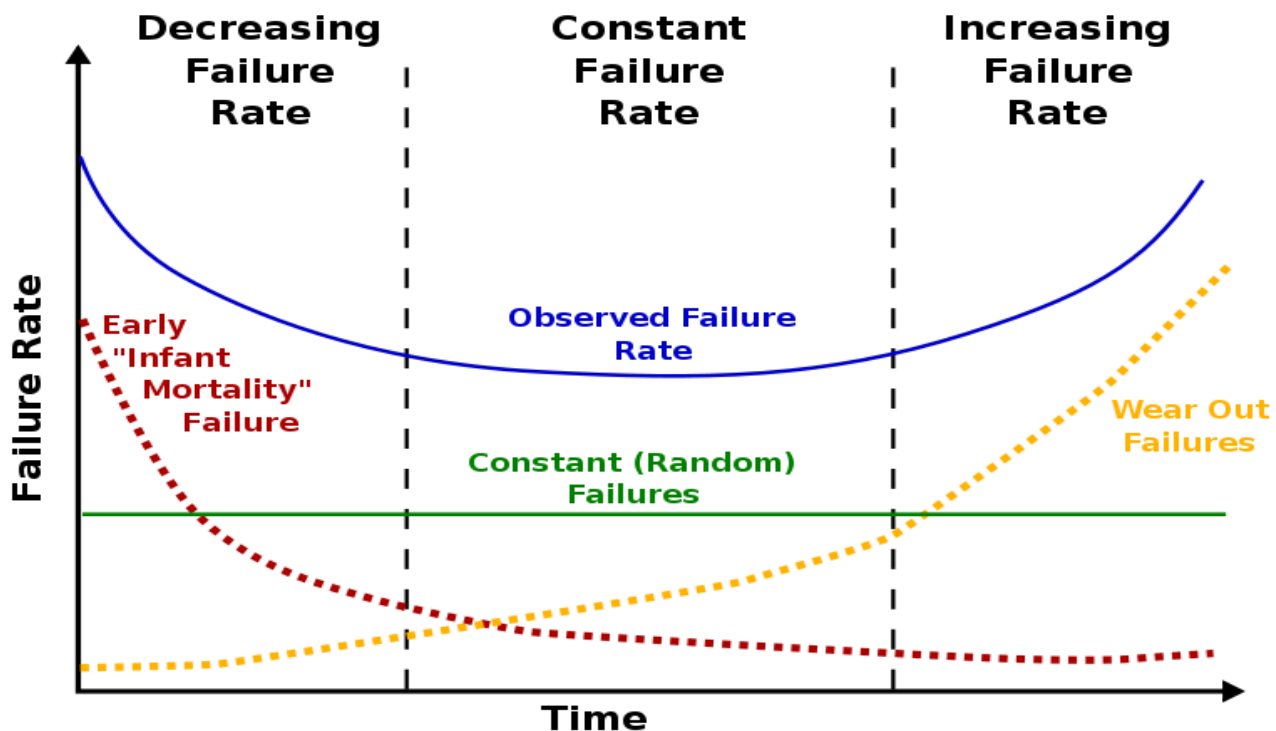

FRL CODE	% per 1000 hours
B	0.1%
C	0.01%
D	0.001%

Red line is characteristic for Tantalum capacitors since there is no wear out mechanism for Ta<sub>2</sub>O<sub>5</sub> dielectric.

# What is Surge Current Screening?

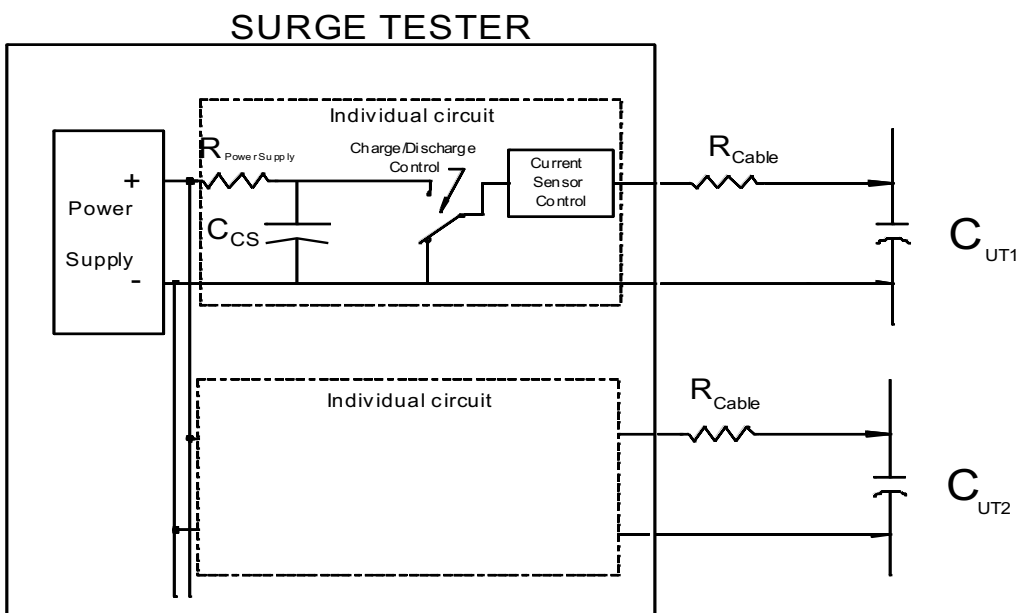

$C_{UTn}$  = Capacitor under test

$C_{CS}$  = Charge Supply Capacitor

$R_{Cable}$  = Cable Resistance (<0.1 ohms)

## Benefits

- Promotes “self healing” in dielectric
- Screens out capacitors with excessively weak dielectrics
- “Heal ‘em or kill ‘em”
- **Surge Test Conditions**
- Full Rated Voltage
- Temperature:
  - +25°C (commercial and Mil)
  - -55°C and +85°C (space)
- Total Circuit Resistance: < 0.5  $\Omega$
- Charge/Discharge Time: 0.1 sec/0.1 sec
- # of Cycles:
  - 3 Cycles (commercial)
  - 10 Cycles (Mil)
  - 10 cycles @ each temp (Space)
- Cap, DF, ESR and DCL are tested 100%

A decorative graphic in the top left corner consisting of a series of blue dots and lines that form a wave-like pattern, extending from the left edge towards the center of the slide.

# Takeaways

# Capacitors Are Not Just Simple, Passive Devices

- Don't Wait To The Last Minute Choosing Your Passives
- Know the strengths and weaknesses of your choice
- One cannot break the laws of physics
- Tantalums are the most volumetrically efficient, stable capacitor available

A decorative graphic consisting of numerous small blue dots arranged in a series of curved, overlapping lines that sweep across the top of the slide from left to right.

Thank you!!!